



---

## Installation Instructions *Rev.02*

---

**READ INSTRUCTIONS THOROUGHLY AND COMPLETELY BEFORE INSTALLATION.**

**INSTALLATION BY A CERTIFIED PROFESSIONAL MECHANIC IS HIGHLY RECOMMENDED.**

**LOGIQ™ IS NOT RESPONSIBLE FOR ANY DAMAGE OR FAILURE RESULTING FROM IMPROPER INSTALLATION.**

### **Warranty**

LOGIQ™ provides a limited lifetime warranty to the original purchaser of products, that the product be free from defects in workmanship and materials when used on cars and trucks as specified by LOGIQ™ and under normal operating conditions. This warranty is subject to the requirements and exclusions set forth in the full Limited Warranty and Return Policy that is available at [logiqair.com/warranty](http://logiqair.com/warranty). Air compressors are a wearing component and are covered by a 2-year warranty from the date of purchase. The warranty does not provide coverage for abuse, operation in a manner not consistent with the product's design, or damage resulting from exposure to the elements.

## Tools Required:

1/2" Wrench  
1/2" Socket & Driver  
Torque Wrench  
Air Line Cutter (or Razor Blade)  
Wire Crimper/Stripper/Cutter  
Electrical Test Light or Meter  
Cut Off Wheel (optional)

## Kit Includes:

(1) AirIQ (SD1/SD2/HD2)  
Air Management  
System with 20 ft  
wiring harness  
pre-installed

(4) Frame Brackets

(4) 5/16"-18 x 5" Hex Bolt  
(4) 5/16"-18 x 3/4" Hex Bolt  
(8) 5/16"-18 Nylock Flanged Nut  
(8) 5/16" Flat Washer  
(1) 30A Fuse & Holder (12AWG)  
(1) 10A Fuse & Holder (16AWG)  
(1) Butt Splice (22-16 AWG)  
(1) Butt Splice (12-10 AWG)

(2) 3/8" Ring Terminal 16 AWG  
(2) 3/8" Ring Terminal 12 AWG  
(1) Small Fuse Tap & Terminal  
(1) Large Fuse Tap & Terminal  
(18 ft) 3/8" Wire Loom  
(20 ft) 1/4" Air Line  
(40) 8" Zip Ties  
(1) Airline Cutter

## Step 1: Mounting

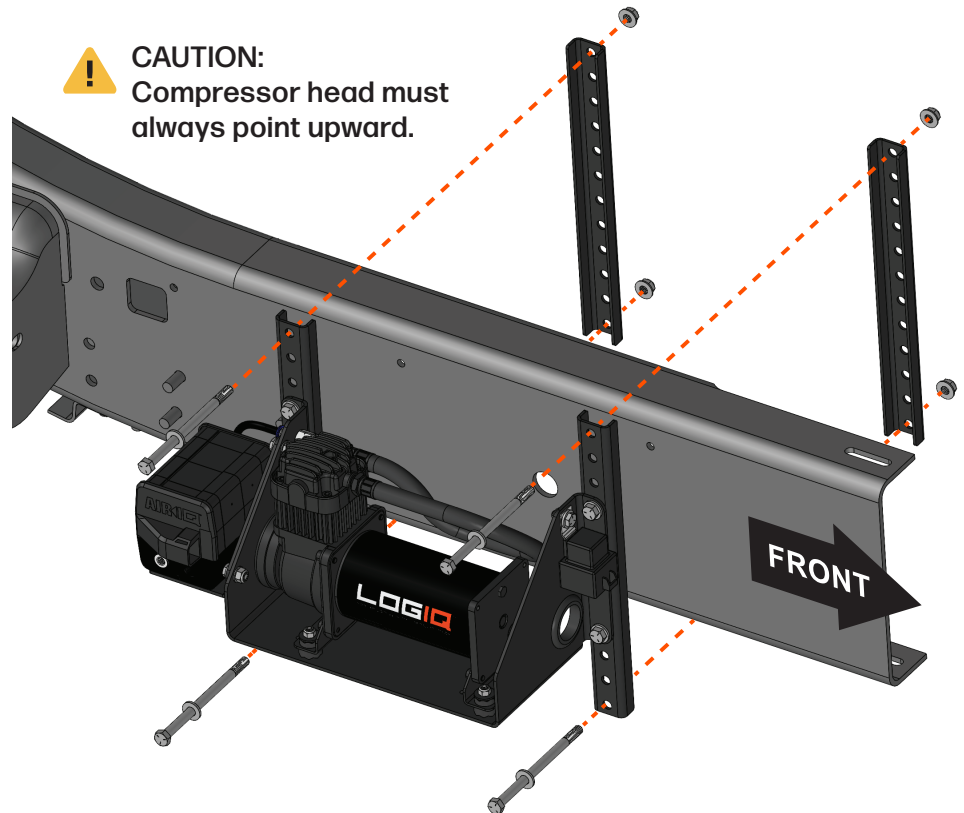
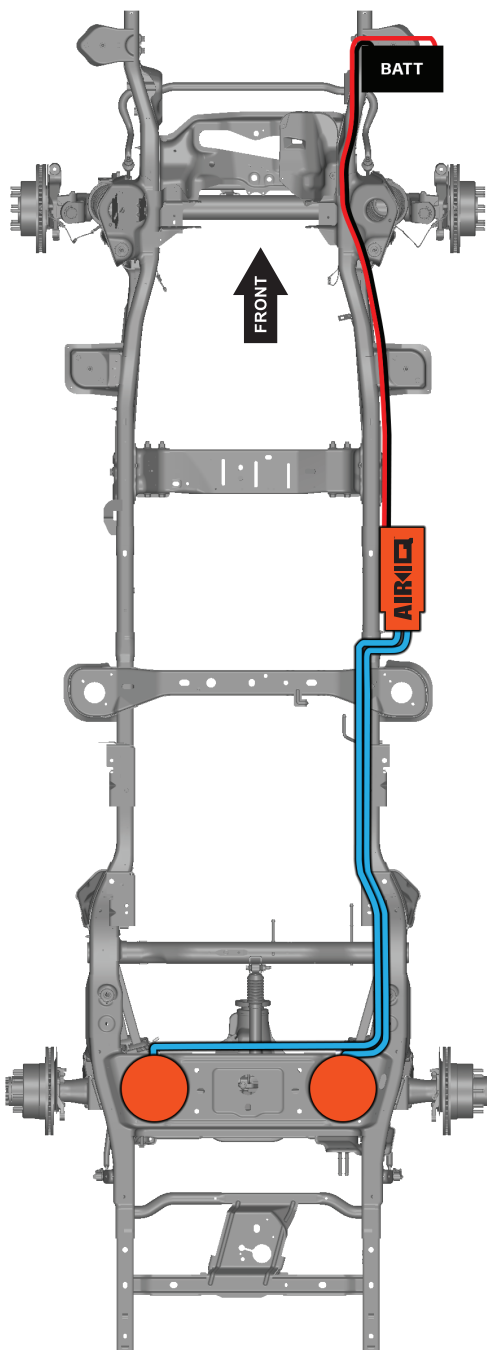

**CAUTION:**  
Compressor head must  
always point upward.

- To determine the assembly height, mock up the frame brackets around the frame as shown and position the AirIQ assembly against the frame brackets to determine which mounting holes may place the assembly in the optimum position (**WARNING: If mounted low, the AirIQ Components may be at higher risk of damage from road debris and if mounted too high the compressor may transfer excessive heat to the floor.**)

**CAUTION:** The compressor gets **HOT** during operation. Ensure a **minimum of 2"** of clear space between the head of the compressor and the nearest component.

- The AirIQ Air Management System is designed to be mounted on the outboard side of the passenger side frame rail with the compressor head pointed UP. If choosing a different mounting location make sure to avoid mounting near high temperature exhaust or areas that risk exposure to road debris.

**Note:** The AirIQ Air Management System is weather-sealed to IP-67 and withstands temperatures between -40C and 85C (-40F to 185F).

## Step 1 (Continued): Mounting

If mounting to a narrow frame (less than 3.25" thick), orient the inboard mounting brackets with the legs of the "C" pointed **TOWARD** the frame. If mounting to a thick frame (greater than 3.25" thick), orient the inboard mounting brackets with the legs of the "C" pointed **AWAY** from the frame.

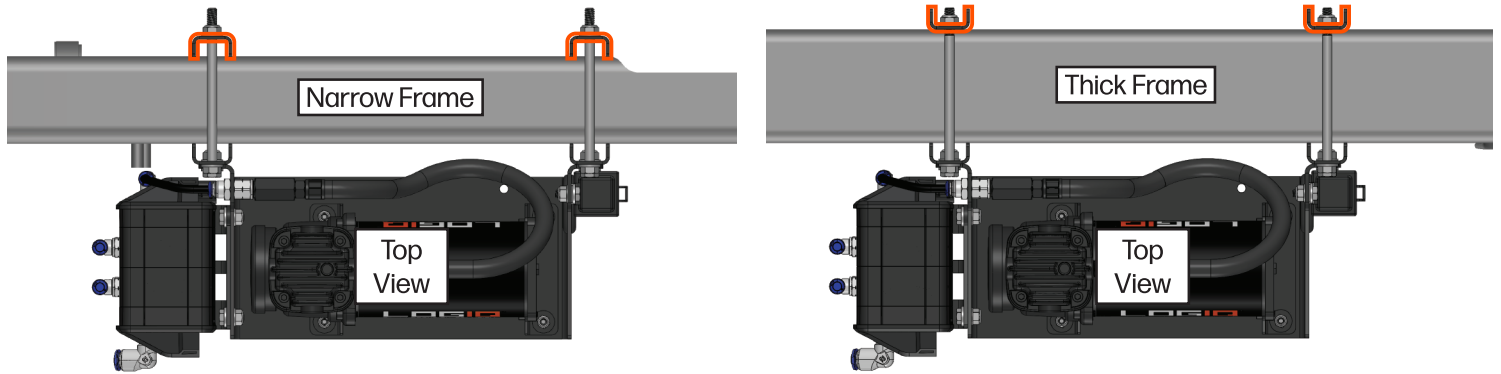

If mounting to a tall frame, use the furthest bolt holes. If mounting to a short frame, use the closest bolt holes to the height of the frame. Then cut the excess material from the bottom of the mounting brackets (paint exposed metal to avoid corrosion). **Torque all mounting hardware to 17 lb. ft.**

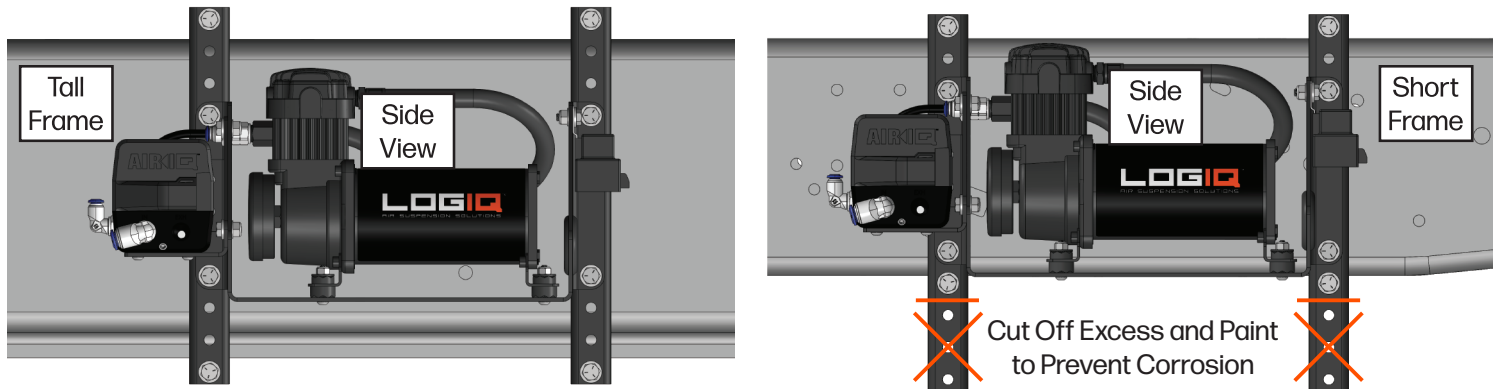

## Step 2: Plumbing

**!** CAUTION: Improper air line cutting can cause permanent damage to the seals of your fittings which will result in air leaks.

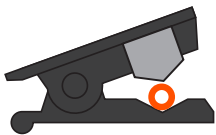

**!** CAUTION: Air Line Cutter contains a sharp blade.

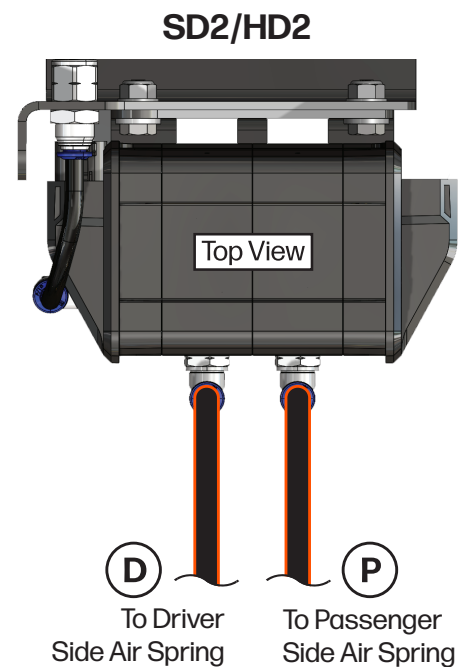
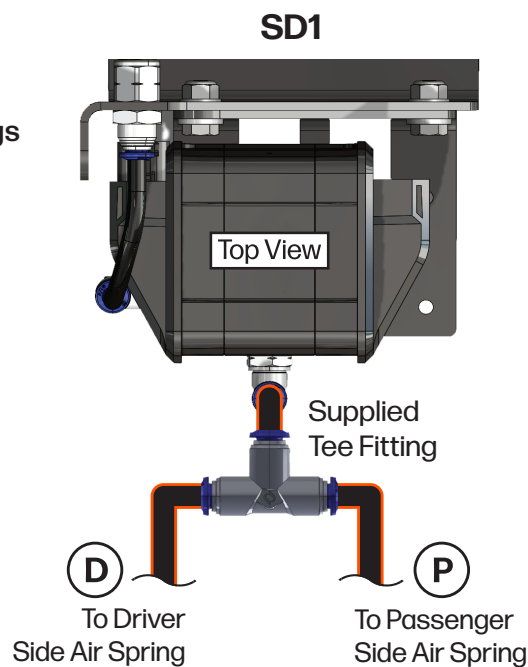

## Step 2 (Continued): Plumbing

Route the supplied air lines from each air spring to the AirIQ module as shown based on system type. Use the supplied zip ties to properly secure the air lines to the frame while avoiding hot exhaust and sharp edges. Use the supplied air line cutter to make clean square cuts to the air line.

**WARNING:** The air line included with your AirIQ Air Management Package is rated for a maximum temperature of 93C (200F). If routed too close to hot exhaust components, the air line may rupture causing the air suspension system to become inoperable.

## Step 3: Wiring

Apply the supplied wire loom around all (5) wires from the AirIQ and route along the frame to the engine compartment. Use supplied zip ties to properly secure the loom while **AVOIDING HOT EXHAUST AND SHARP EDGES** that could damage the loom or wires.

- Use the supplied Ring Terminals to connect both **BLACK** wires to the **NEGATIVE** battery terminal.
- Connect one side of the supplied Fuse Holders to the matching size **RED** wires with the supplied Butt Splice Terminals and connect the other end of the Fuse Holders to the **POSITIVE** battery terminal with the supplied Ring Terminals.
- Use an electrical test light or meter to find a fuse in the vehicle fuse block that turns **ON** when the ignition is **ON** and turns **OFF** when the ignition is **OFF** (the amperage rating of the fuse that you choose is not important). Use the supplied Fuse Tap (large or small depending on your vehicle's fuse size) to connect the **ORANGE** wire to this fuse location.

**Note:** The **ORANGE** wire for the AirIQ Air Management System does not draw any current, only signal.

**CAUTION:** If the **ORANGE** wire is not connected to 12Volts, the AirIQ will not turn ON. If the **ORANGE** wire is accidentally connected to full-time battery 12Volts, the AirIQ will not turn OFF.

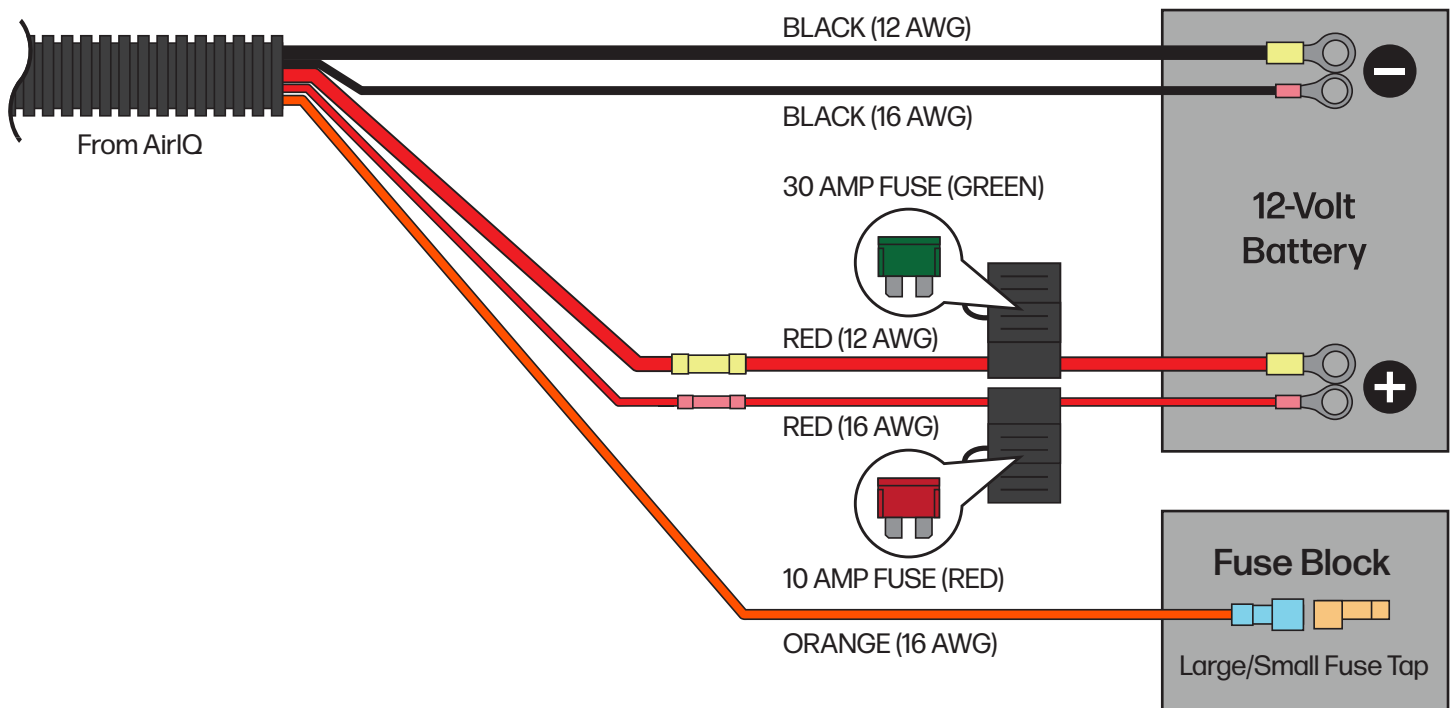

The AirIQ Air Management System is now ready to be powered and tested:

- Install the **GREEN 30 AMP FUSE** into the **12 AWG** Fuse Holder.
- Install the **RED 10 AMP FUSE** into the **16 AWG** Fuse Holder.
- Turn the Vehicle **Ignition ON** and proceed.

## Step 4: App Connection

- Download the **LOGIQ AirIQ** Application for free from the Apple App Store\* or Google Play Store\*\*. Be sure to upgrade the app whenever available to receive the latest features and functions.
- With the vehicle's **Ignition ON**, Enable Bluetooth on the smart device (Settings>Bluetooth>ON) and **OPEN** the LOGIQ AirIQ Application.
- The App will automatically connect to the AirIQ system (AirIQ-XXXX) and automatically recognize the system configuration (SD1/SD2/HD2).
- If the AirIQ system requires a mandatory firmware update, this process will begin automatically immediately following App connection. Keep the phone near the AirIQ for best connectivity and leave the Ignition ON. This process may take up to 20 minutes with older phones.

**Note: The AirIQ App requires enabling "Location" for the purpose of finding nearby AirIQ Bluetooth devices.**

## Step 5: Setup & Testing

**Tank Attached** - If a tank is present in the system, change **Menu>Tank Attached>ON**. The factory setting for pressure range is 110-150 psi. If using a compressor rated for higher pressures, the pressure range may be changed to 135-175 psi or 160-200 psi using **Menu>Set Pressure Range**.



**SD1** Press the inflate button to Inflate both rear air springs to 50 psi.

**SD2/HD2** Press the left rear inflate button and make sure that the Driver side rear air spring inflates (if the Passenger side inflates then swap the air line orientation at the AirIQ). Then inflate both rear air springs to 50 psi.

**LEAK TEST** the installation by spraying soapy water around all of the pneumatic fittings while watching for bubbles.

**Note: The AirIQ Air Management System is leak tested from the factory. Most leaks that occur during installation occur between the air line and the fitting due to improper air line cutting. If the o-ring inside of the fitting has been damaged then contact customer service to order a replacement.**

## Step 6: Operation

Manual Inflation/Deflation:

**WARNING:** Before manually inflating or deflating the system, make sure that the vehicle is clear of persons or obstructions. Failure to do so may result in death, injury, or physical damage.

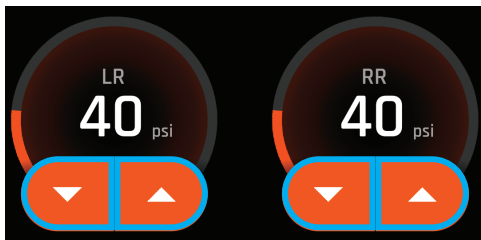

Use the **UP/DOWN** Arrows to momentarily adjust individual corners.

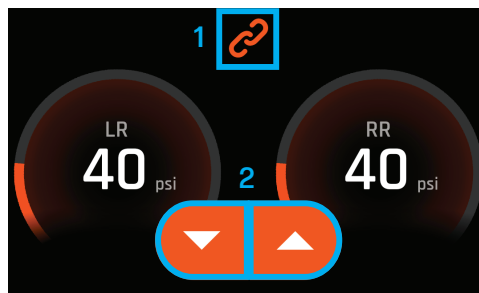

Or use the **LINK** button to adjust both corners at the same time.

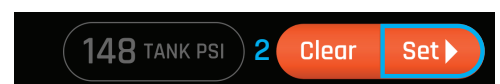
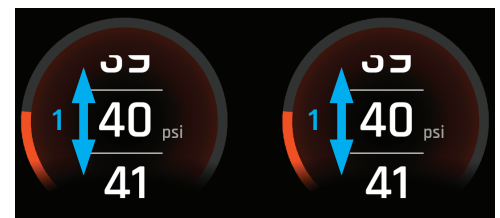

Or use the Ticker Selector by pressing one of the air spring pressure displays. Adjust the **TICKER** to the desired pressure(s) and press **>SET** in the lower right hand corner.

\* "Apple App Store" is a trademark of Apple Inc.

\*\* "Google Play Store" is a trademark of Alphabet Inc.

## Step 6 (Continued): Operation

### Automatic Inflation/Deflation (Presets):

**! WARNING:** Before automatically inflating or deflating the system, make sure that the vehicle is clear of persons or obstructions. Failure to do so may result in death, injury, or physical damage. LOGIQ™ cannot guarantee the accuracy of automatic adjustments. It is the user's responsibility to confirm that the air suspension is at the desired pressure settings prior to operating the vehicle.

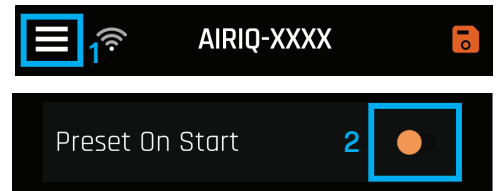
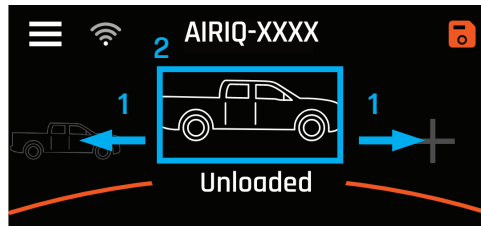

Save up to 8 preset pressure settings to fit different vehicle loading or use cases. To save a new preset, simply manually inflate/deflate to the desired pressures, then slide the carousel to the desired position and press **>SAVE**. Name the preset and associate it with an icon from the list.

To recall a preset, slide the carousel to the desired preset and press it.

**Preset on Start**- The AirIQ system will automatically readjust to the last preset it was at when the ignition is switched ON if this feature is enabled

**Menu>Preset On Start.**

**Note: Preset On Start does not function after the system has exceeded the Sleep Timeout.**

### System Settings:

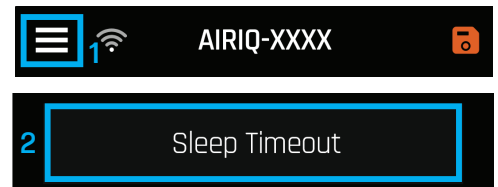
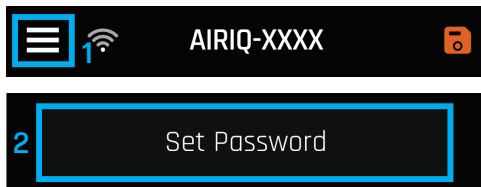

**Device Password** - The AirIQ system was shipped without a password and will connect to any AirIQ App that also does not have a password set. To avoid allowing other people with the AirIQ App to control the system, set a custom password with **Menu>Set Password>Save**. Multiple smart devices (phones, etc) can connect to the same AirIQ by inputting this same password into all of them. Clear the password with **Menu>Set Password>Clear**.

**Device Name** - The AirIQ was shipped with a unique device name AirIQ-XXXX. Change this name to your preference with **Menu>Device Name**. This is convenient when trying to identify a specific AirIQ system amongst others.

**Sleep Timeout** - The AirIQ system will operate for up to 24 hours after turning the ignition OFF. After this time, the system will go into deep sleep to prevent battery drain. Adjust the Sleep Timeout Period with **Menu>Sleep Timeout** if desired.

**Note: In the case of a lost phone and forgotten password, clear the password by cycling the ignition switch 5 times in a row (each time within 3 seconds of each other).**



## Warnings and Disclaimers

### Safety Warnings

#### **MISUSE OF THIS PRODUCT COULD LEAD TO INJURY OR DEATH.**

Suspension systems or components that enhance the on and off-road performance of your vehicle may cause it to handle differently than it did from the factory. Extreme care must be used to prevent loss of control during abrupt maneuvers.

Always operate your vehicle at reduced speeds to ensure your ability to control your vehicle under all driving conditions. Failure to drive safely may result in serious injury or death.

Driver and passengers must **ALWAYS** wear seat belts, avoid quick sharp turns and other sudden maneuvers. LOGIQ™ does not recommend the combined use of suspension lifts, body lifts, or other lifting devices.

You should never operate your vehicle under the influence of alcohol or drugs.

Constant maintenance is required to keep your vehicle safe. Thoroughly inspect your vehicle before and after every off-road use.

It is the responsibility of the retailer and/or the installer to review all state and local laws, with the end user of this product, related to bumper height laws and the lifting of their vehicle before the purchase and installation of any LOGIQ™ products.

Raised vehicles have altered viewing angles than stock vehicles. This can lead to larger or different blind spots than the driver is accustomed. It is the responsibility of the driver to be aware of this and check their surroundings at all times while the vehicle is in motion and immediately prior to operating vehicle. Failure to do so can lead to damages, injury, or death.

### Installation Warning

All steps and procedures described in these instructions were performed while the vehicle was properly supported on a two post vehicle lift with safety jacks.

Use caution during all disassembly and assembly steps to ensure suspension components are not over extended causing damage to any vehicle components and parts included in this kit.

Included instructions are guidelines only for recommended procedures and are not meant to be definitive. Installer is responsible to insure a safe and controllable vehicle after performing modifications.

LOGIQ™ recommends the use of an OE Service Manual for model/year of vehicle when disassembly and assembly of factory and related components.

Unless otherwise specified, tighten all bolts and fasteners to standard torque specifications listed within the OE Service Manual.

Suspension components that use rubber or urethane bushings should be tightened with the vehicle at normal ride height. This will prevent premature wear or failure of the bushing and maintain ride comfort.

Larger tire and wheel combinations may increase leverage on suspension, steering, and related components.

Due to payload options and initial ride height variances, the amount of lift/lower is a base figure. Final ride height dimensions may vary in accordance to original vehicle ride height. Always measure the vehicle ride height prior to beginning installation.

## Warnings and Disclaimers

### SAEJ2492 Warning

By installing this product, you acknowledge that the suspension of this vehicle has been modified. As a result, this vehicle may handle differently than that of factory-equipped vehicles. As with any vehicle, extreme care must be used to prevent loss of control or roll-over during sharp turns or abrupt maneuvers. Always wear seat belts, and drive safely, recognizing that reduced speeds and specialized driving techniques may be required. Failure to drive this vehicle safely may result in serious injury or death. Do not drive this vehicle unless you are familiar with its unique handling characteristics and are confident of your ability to maintain control under all driving conditions. Some modifications (and combinations of modifications) are not recommended and may not be permitted in your state. Consult your owner's manual, the instructions accompanying this product, and state laws before undertaking these modifications. You are responsible for the legality and safety of the vehicle you modify using these components.

### Headlamp Warning

A lifted or lowered vehicle may have different headlight aim performance. LOGIQ™ recommends marking and recording the headlight beam position before kit installation and then adjusting, if necessary, the headlamps to the same height settings after kit installation. Set the vehicle on a level surface 10' to 15' from a solid wall or garage door. (This is a general distance with some manufacturers requiring different distances.) Note the top height of the low beam's bright spot, the top of the most intense part of the beam, for driver and passenger side. Height may vary from side to side. Repeat this procedure and adjust after lift kit is installed. Adjust if the aim is off by turning the adjusters gradually (a quarter of a turn) and looking to see where the new alignment falls. It may be easier to block one headlamp while adjusting the other. Consult the owner operation manual for procedures to adjust headlights - many automakers offer headlight aiming specs. Some states have their own specifications when it comes to headlight aim, so it's best to follow those rules when aligning headlights.

**FAILURE TO PERFORM THE POST INSPECTION CHECKS MAY RESULT IN VEHICLE COMPONENT DAMAGE AND/OR PERSONAL INJURY OR DEATH TO THE DRIVER AND/OR OTHERS.**

### Final Checks & Adjustments

Once the vehicle is lowered to the ground, check all parts which have rubber or urethane components to ensure proper torque. Torque lug nuts to the wheel manufacturer specs. Move vehicle backwards and forwards a short distance to allow suspension components to adjust. Turn the front wheels completely left then right and verify adequate tire, wheel, brake line, and ABS wire clearance. Test and inspect steering, brake and suspension components for tightness and proper operation. Inspect brakes hoses and ABS lines for adequate slack at full extension, adjust as necessary.

**RECHECK ALL HARDWARE FOR PROPER TORQUE VALUES AFTER 500 MILES, AND THEN PERIODICALLY AT EACH SERVICE INTERVAL THEREAFTER.**

### Vehicle Handling Warning

Increasing the height of your vehicle raises the center of gravity and can affect stability and control. Use caution on turns and when making steering corrections.

Vehicles with larger tires and wheels will handle differently than stock vehicles. Take time to familiarize yourself with the handling of your vehicle.

### Wheel Alignment/Headlamp Adjustment

It is necessary to have a proper and professional wheel alignment performed by a certified alignment technician. Align the vehicle to factory specifications. It is recommended that your vehicle alignment be checked after any off-road driving.

In addition to your vehicle alignment, for your safety and others, it is necessary to check and adjust your vehicle headlamps for proper aim and alignment. If the vehicle is equipped with active or passive safety/collision monitoring and/or avoidance systems including, but not limited to, camera- or radar-based systems, check and adjust your vehicle's systems for proper aim and function.